



A. Koch

# Eingebettete Prozessorarchitekturen

## 9. Entwurf mit rekonfigurierbaren Prozessoren

Andreas Koch

FG Eingebettete Systeme und ihre Anwendungen  
Informatik, TU Darmstadt

Wintersemester 2007/2008



- Auszüge aus Trainingsmaterial der Fa. Stretch
  - Insbesondere alle Zeichnungen und technischen Daten
- Material ist **vertraulich**
  - Nur für die Lehre zur Verfügung gestellt
  - Darf **nicht** weiterverbreitet werden

# Zwischenstand



A. Koch

- Stretch S5000 Architektur
- Programmierung in Stretch-C
- Flächen- und Zeitabschätzungen



A. Koch

# Pipelining

# Unterschiedliche Taktbereiche

*clock domains*



A. Koch

- Feste Xtensa V Pipeline läuft mit max. 300 MHz
- Rekonfigurierbare ISEFs laufen mit max. 100 MHz
- Starte eine ISEF EI **je zwei** Xtensa V Instruktionen
- Xtensa Speichertransfers **während** EI-Ausführungszeit

## Beispiel

### Schleife entrollt

```
WRGETOI (&A, 15)  
rgb2ycc (A, &B)  
WRPUTI (B, 15)  
WRGETOI (&A, 15)  
rgb2ycc (A, &B)  
WRPUTI (B, 15)
```

### Spannender Teil

```
rgb2ycc (A, &B)  
WRPUTI (B, 15)  
WRGETOI (&A, 15)
```

**Während** Ausführungszeit von `rgb2ycc` werden alte Daten geschrieben und neue geholt.

# Pipeline-Struktur

Bis zu 31 Takte lang



A. Koch

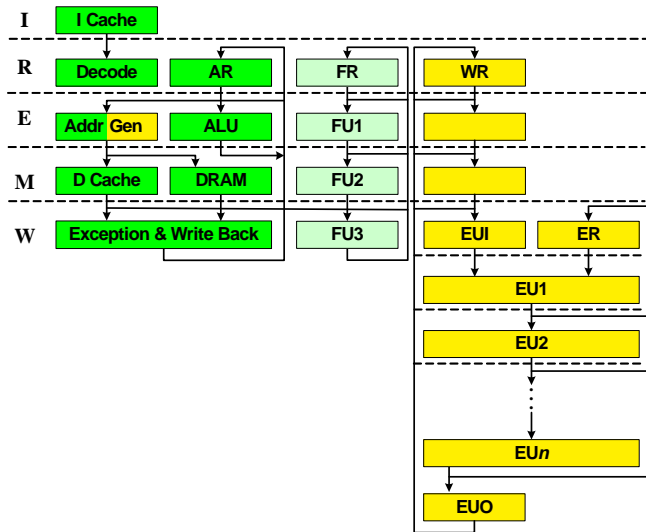

# Pipeline-Ablauf im ISEF



A. Koch

- Operanden werden **am Anfang** von EUI-Stufe gelesen (*input*)
- Ergebnisse werden **am Ende** von EUO-Stufe ausgegeben (*output*)
- EI mit  $n$ -Takten hat Stufen EUI, EU1, ..., EU $n$ , EUO
- $n$  ist hier in Xtensa-Takten, i.d.R. ISEF-Takte =  $n/3$
- Extension Registers dürfen ...
  - am Anfang jeder EU $i$ -Stufe gelesen werden
  - am Ende jeder EU $j$ -Stufe mit  $j \geq i$  geschrieben werden
- Alle Register (AR, WR, ER) sind
  - **Interlocked**: ISEF-Pipeline hält an, wenn RAW verletzt
  - **Bypassed**: Register sofort nach Definition verwendbar

# Beispiel Pipelining



A. Koch

```

for (i = 0; i < NP/5; i++) {
    WRGETOI(&A, 15); // load available after M
    rgb2ycc(A, &B); // rgb2ycc's latency is 10 cycles (2*3 + 4)
    WRPUTI(B, 15); // B must be available before E
}
    
```

Compute-store stall for B

Note Zero Overhead Loop  
Each iteration takes 12 cycles

n		0	1	2	3	4	5	6	7	8	9	10	11	12	13	14	15	16	17	18	19	20	
0	WRGETOI	I	R	E	M	W																	
0	rgb2ycc		I	R	E	M	EU1	EU2	EU3	EU4	EU5	EU6	EU0										
0	WRPUTI			I	R	-	-	-	-	-	-	-	-	-	E	M	W						
1	WRGETOI				I	-	-	-	-	-	-	-	-	-	R	E	M	W					
1	rgb2ycc														I	R	E	M	EU1	EU2	EU3		



# Komplizierteres Szenario mit Loop Unrolling



A. Koch

## Unrolling im Compiler abgeschaltet:

Instruction	1	2	3	4	5	6	7	8	9	10	11	12	13	14	15	16	17	18	19	20	21
movi a8, 128	I	R	E	M	W																
vrpbitn 0, a3		I	R	E	M	W															
vrget0init0, a2			I	R	E	M	W														
vrget0init1				I	R	E	M	W													
loopgtz a8, d00015c					I	R	E	M	W												
vrget0 vrna0, 15						I	R	E	M	W											
se_rpb2ycyc vrna0, vrna1							I	R	E	M	W										
vrputi vrna0, 15								I	R	E	M	W									
									I	R	E	M	W								

Stalls highlighted

3 instructions  
= 12 cycles  
(9 stalls)

Zero-overhead loop instruction

## Unrolling erlaubt:

Instruction	1	2	3	4	5	6	7	8	9	10	11	12	13	14	15	16	17	18	19	20	21	22	23	24
se_rpb2ycyc vrna3, vrna3	I	R	E	M	W																			
loopgtz a8, d00015bc		I	R	E	M	W																		
vrget0 vrna0, 15			I	R	E	M	W																	
se_rpb2ycyc vrna4, vrna5				I	R	E	M	W																
vrget0 vrna2, 15					I	R	E	M	W															
vrputi vrna7, 15						I	R	E	M	W														
se_rpb2ycyc vrna6, vrna7							I	R	E	M	W													
vrputi vrna1, 15								I	R	E	M	W												
vrget0 vrna4, 15									I	R	E	M	W											
se_rpb2ycyc vrna0, vrna1										I	R	E	M	W										
vrputi vrna3, 15											I	R	E	M	W									
vrget0 vrna6, 15												I	R	E	M	W								
se_rpb2ycyc vrna2, vrna3													I	R	E	M	W							
vrputi vrna5, 15														I	R	E	M	W						

12 instructions  
= 12 cycles  
(0 stalls)



A. Koch

# Loop Unrolling

# Idee beim Loop Unrolling



A. Koch

- Beobachtung
  - Latenz einer  $n$ -Takte EI ist  $n + 2$  Takte (EUI+EUI)
  - $n$ -Takte EI gefolgt von STORE hat Latenz  $n + 4$
- Idee
  - Ur-Schleife von  $N$  Iterationen entrollen um Faktor  $M$
  - Nun  $M$  Datenelemente je Iteration rechnen
  - Dafür aber nur noch  $N/M$ -Iterationen ausführen
  - Wartezyklen mit sinnvollen Operationen füllen
    - Jetzt genug im Schleifenrumpf vorhanden

# Rezept für Loop Unrolling



A. Koch

- 1  $M$  Kopien des Rumpfes in Schleife anlegen
  - Jede mit **eigenem** Satz Variablen
  - Verschiebe STORE-Anweisungen genau **vor** Berechnung
  - Nun Grenzen auf  $N/M - 1$  Iterationen setzen
    - Eine Iteration realisiert in Prolog/Epilog
- 2 Kopiere neuen Rumpf vor Schleife als **Prolog**
  - Lösche alle **STOREs** in Prolog
- 3 Kopiere neuen Rumpf hinter Schleife als **Epilog**
  - Lösche dabei alles **ausser** STOREs

# Beispiel: rgb2ycc-Schleife



A. Koch

```

for (i = 0; i < NP/5; i++) {
    WRGETOI(&A, 15); // load available after M
    rgb2ycc(A, &B); // rgb2ycc's latency is 10 cycles (2*3 + 4)
    WRPUTI(B, 15); // B must be available before E
}
    
```

Compute-store stall for B

Note Zero Overhead Loop  
Each iteration takes 12 cycles

n		0	1	2	3	4	5	6	7	8	9	10	11	12	13	14	15	16	17	18	19	20	
0	WRGETOI	I	R	E	M	W																	
0	rgb2ycc		I	R	E	M	EU1	EU2	EU3	EU4	EU5	EU6	EU0										
0	WRPUTI			I	R	-	-	-	-	-	-	-	-	-	E	M	W						
1	WRGETOI				I	-	-	-	-	-	-	-	-	-	R	E	M	W					
1	rgb2ycc														I	R	E	M	EU1	EU2	EU3		

# Beispiel: Schleife entrollt um $M = 4$



A. Koch

```
WRGETOI(&A0, 15);           // load A0
rgb2ycc(A0, &B0);           // convert A0
WRGETOI(&A1, 15);           // load A1
rgb2ycc(A1, &B1);           // convert A1
WRGETOI(&A2, 15);           // load A2
rgb2ycc(A2, &B2);           // convert A2
WRGETOI(&A3, 15);           // load A3
rgb2ycc(A3, &B3);           // convert A3

for (i = 1; i < NPIX5/4; i++) {
    WRGETOI(&A0, 15);       // load A0
    WRPUTI(B0, 15);         // store B0
    rgb2ycc(A0, &B0);       // convert A0->B0

    WRGETOI(&A1, 15);       // load A1
    WRPUTI(B1, 15);         // store B1
    rgb2ycc(A1, &B1);       // convert A1->B1

    WRGETOI(&A2, 15);       // load A2
    WRPUTI(B2, 15);         // store B2
    rgb2ycc(A2, &B2);       // convert A2->B2

    WRGETOI(&A3, 15);       // load A3
    WRPUTI(B3, 15);         // store B3
    rgb2ycc(A3, &B3);       // convert A3->B3
}

WRPUTI(B0, 15);             // store B0
WRPUTI(B1, 15);             // store B1
WRPUTI(B2, 15);             // store B2
WRPUTI(B3, 15);             // store B3
```

# Beispiel: Details des Entrollens



i starts at 1, goes to max/4

A. Koch

```
WRGETOI(&A0, 15);           // load A0
rgb2ycc(A0, &B0);           // convert A0
WRGETOI(&A1, 15);           // load A1
rgb2ycc(A1, &B1);           // convert A1
WRGETOI(&A2, 15);           // load A2
rgb2ycc(A2, &B2);           // convert A2
WRGETOI(&A3, 15);           // load A3
rgb2ycc(A3, &B3);           // convert A3

for (i = 1; i < NPIX5/4; i++) {
  WRGETOI(&A0, 15);         // load A0
  WRPUTI(B0, 15);          // store B0
  rgb2ycc(A0, &B0);        // convert A0->B0

  WRGETOI(&A1, 15);         // load A1
  WRPUTI(B1, 15);          // store B1
  rgb2ycc(A1, &B1);        // convert A1->B1

  WRGETOI(&A2, 15);         // load A2
  WRPUTI(B2, 15);          // store B2
  rgb2ycc(A2, &B2);        // convert A2->B2

  WRGETOI(&A3, 15);         // load A3
  WRPUTI(B3, 15);          // store B3
  rgb2ycc(A3, &B3);        // convert A3->B3
}

WRPUTI(B0, 15);            // store B0
WRPUTI(B1, 15);            // store B1
WRPUTI(B2, 15);            // store B2
WRPUTI(B3, 15);            // store B3
```

```
WRGETOI(&A0, 15);           // load A0
```

# Beispiel: Ergebnis



A. Koch

Instruction	1	2	3	4	5	6	7	8	9	10	11	12	13	14	15	16	17	18	19	20	21	22	23	24
loopgz a0, d000157d	I	R	E	M	W																			
wrapubi wra3, 15		I	R	E	M	W																		
wraget0i wra3, 15			I	R	E	M	W																	
se_rgbzyc cc wra3, wra3				I	R	E	M	EU1	EU1	EU2	EU3	EU4	EU5	EU6	EU0									
wrapubi wra2, 15					I	R	E	M	W															
wraget0i wra2, 15						I	R	E	M	W														
se_rgbzyc cc wra2, wra2							I	R	E	M	EU1	EU1	EU2	EU3	EU4	EU5	EU6	EU0						
wrapubi wra1, 15								I	R	E	M	W												
wraget0i wra1, 15									I	R	E	M	W											
se_rgbzyc cc wra1, wra1										I	R	E	M	EU1	EU1	EU2	EU3	EU4	EU5	EU6	EU0			
wrapubi wra0, 15											I	R	E	M	W									
wraget0i wra0, 15												I	R	E	M	W								
se_rgbzyc cc wra0, wra0													I	R	E	M	EU1	EU1	EU2	EU3	EU4	EU5	EU6	EU0

- Nun keine Stall-Zyklen mehr
- Vorher: 12 Takte je Iteration
- Nun: 12 Takte je **4** Iterationen





A. Koch

# Optimierung von EIs

# Beispiel: Maximaler 16b-Wert in Array

El bearbeitet je 8 Werte



A. Koch

```
#define N (8)
SE_FUNC void runningmax ( SE_INST MAX8_INIT, SE_INST MAX8, WRA IN, WRA *OUT )
{
    int i;
    static se_sint<16> acc;
    se_sint<16> x[N];

    for (i = 0; i < N; i++) x[i] = IN(i*16 + 15, i*16);

    acc = MAX8_INIT ? -32768 : acc;
    for (i = 0; i < N; i++) {
        if (x[i] > acc) acc = x[i];
    }

    (*OUT)(15,0) = acc;
}
```

```
INSTRUCTION=runningmax:MAX8 Opcode: 1: Assembly 'se_max8 IN:in, OUT:in+OUT:out'
Input : variable 'IN' read from WRA on ISEF read port 1 at beginning of cycle 1
Input : variable 'OUT' read from WRA on ISEF read port 0 at beginning of cycle 1
Output: variable 'OUT' written to WRA on ISEF write port 0 at end of cycle 5
ISEF Local State variable 'acc.0' (16 bits) read at beginning of cycle 2
ISEF Local State variable 'acc.0' (16 bits) written at end of cycle 4
                                     (Write-Read = 2)
```

# Beispiel: Erzeugte Hardware



A. Koch

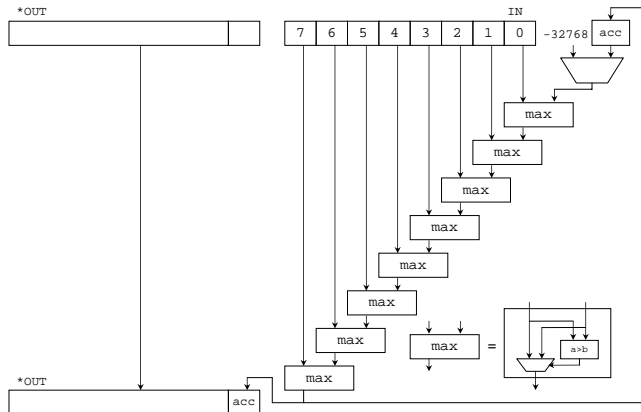

- **\*OUT** wird versehentlich auch gelesen
- Berechnung von **max** erfolgt hier seriell
- Langer Zeitraum zwischen Lesen/Schreiben von **acc**
  - Potentiell lange Interlock-Delays → **niedriger Durchsatz**

# Beispiel: Verbesserte Version



A. Koch

```
#define MYMAX(a, b) (((a) > (b)) ? (a) : (b))
#define N (8)
SE_FUNC void somecode ( SE_INST MAX8_INIT, SE_INST MAX8, WRA IN, WRA *OUT )
{
    int i;
    static se_sint<16> acc;
    se_sint<16> max, x[N];

    for (i = 0; i < N; i++) x[i] = IN(i*16 + 15, i*16);

    max = MYMAX( MYMAX( MYMAX(x[0], x[1]), MYMAX(x[2], x[3]) ),
                MYMAX( MYMAX(x[4], x[5]), MYMAX(x[6], x[7]) ) );
    acc = MAX8_INIT ? -32768 : MYMAX(max, acc);

    (*OUT) = 0;
    (*OUT)(15,0) = acc;
}
```

```
INSTRUCTION=somecode:MAX8 Opcode: 1: Assembly 'se_max8 IN:in, OUT:out'
Input : variable 'IN' read from WRA on ISEF read port 1 at beginning of cycle 1
Output: variable 'OUT' written to WRA on ISEF write port 0 at end of cycle 5
ISEF Local State variable 'acc.0' (16 bits) read at beginning of cycle 3
ISEF Local State variable 'acc.0' (16 bits) written at end of cycle 3
                                           (Write - Read = 0)
```

# Beispiel: Verbesserte Hardware



A. Koch

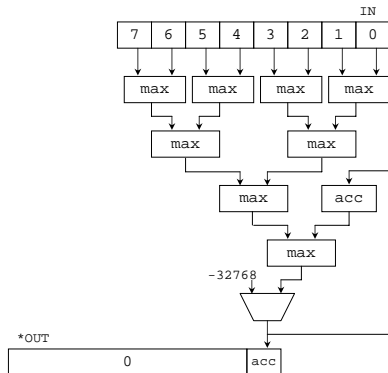

- Oberste 112b von **\*OUT** nun nicht mehr gelesen
  - Direkt auf 0 gesetzt
- **max**-Berechnung erfolgt weitgehend parallel
- Nun minimales Zeitintervall Lesen/Schreiben **acc**
  - Keine Interlock-Delays mehr → **höherer Durchsatz**

# Allgemeine Tipps



A. Koch

- Setze Variablen auf **passende** Größe
  - Beispiel: `se_sint<18>` statt `int`
- Spezifiziere **alle** Alternativen bei Verzweigungen
  - Zu jedem `if` ein **else**
  - In jedem `switch` ein **default**
  - ➔ ähnlich zu Verilog (kommt noch!)
- Setze **alle** Bits in Variablen

# Konstantentabellen in Stretch-C



A. Koch

- Werden in verschiedensten Situationen eingesetzt
  - Ersetze Berechnung durch Nachschlagen (*lookup*)
  - $\sin x$ ,  $\log x$ , ...
  - Routing-Tabellen
  - Zustandsautomat (in mehreren EI-Aufrufen ausgeführt)
- Im ISEF **nicht** durch Speicher (RAM/ROM) realisiert
- Sondern durch kombinatorische Logik
  - Logikminimierung möglich (ggf. sehr rechenaufwendig!)

# Konstantentabellen 1

## Beispiel



A. Koch

```
// GF 8-bit inverse and affine for AES encryption
static const char gf_invaffine_enc[256] = {
    0x63, 0x7c, 0x77, 0x7b, 0xf2, 0x6b, 0x6f, 0xc5, 0x30, 0x01, 0x67, 0x2b, 0xfe, 0xd7, 0xab, 0x76,
    0xca, 0x82, 0xc9, 0x7d, 0xfa, 0x59, 0x47, 0xf0, 0xad, 0xd4, 0xa2, 0xaf, 0x9c, 0xa4, 0x72, 0xc0,
    0xb7, 0xfd, 0x93, 0x26, 0x36, 0x3f, 0xf7, 0xcc, 0x34, 0xa5, 0xe5, 0xf1, 0x71, 0xd8, 0x31, 0x15,
    ...
    0x8c, 0xa1, 0x89, 0x0d, 0xbf, 0xe6, 0x42, 0x68, 0x41, 0x99, 0x2d, 0x0f, 0xb0, 0x54, 0xbb, 0x16
};

SE_FUNC void AES_TABLE_LOOKUP( WRA in, WRA *out )
{
    int i;
    se_uint<8> x, y;

    *out = 0;
    for ( i = 3; i >= 0; i-- ) {
        x = in(8*i+7, 8*i);          /* PIPELINE=108 LOGIC=696 MUX=633 CYCLE=5 */
        y = gf_invaffine_enc[integer(x)]; /* PIPELINE=36 LOGIC=106 MUX=207 CYCLE=5 */
        *out = (*out, y);
    }
}

/*          Final resource usage report          */
/* Total AUs = 1759 out of 4096                */
/* Total MUs = 0 out of 8192                    */
```



# Beispiel: Konstantentabellen 1

## Diskussion



A. Koch

```
// GF 8-bit inverse and affine for AES encryption
static const char gf_invaffine_enc[256] = {
    0x63, 0x7c, 0x77, 0x7b, 0xf2, 0x6b, 0x6f, 0xc5, 0x30, 0x01, 0x67, 0x2b, 0xfe, 0xd7, 0xab, 0x76,
    0xca, 0x82, 0xc9, 0x7d, 0xfa, 0x59, 0x47, 0xf0, 0xad, 0xd4, 0xa2, 0xaf, 0x9c, 0xa4, 0x72, 0xc0,
    0xb7, 0xfd, 0x93, 0x26, 0x36, 0x3f, 0xf7, 0xcc, 0x34, 0xa5, 0xe5, 0xf1, 0x71, 0xd8, 0x31, 0x15,
    ...
    0x8c, 0xa1, 0x89, 0x0d, 0xbf, 0xe6, 0x42, 0x68, 0x41, 0x99, 0x2d, 0x0f, 0xb0, 0x54, 0xbb, 0x16
};

SE_FUNC void AES_TABLE_LOOKUP( WRA in, WRA *out )
{
    int i;
    se_uint<8> x, y;

    *out = 0;
    for ( i = 3; i >= 0; i-- ) {
        x = in(8*i+7, 8*i);
        y = gf_invaffine_enc[integer(x)];
        *out = (*out, y);
    }
}

/* Final resource usage report */
/* Total AUs = 1759 out of 4096 */
/* Total MUs = 0 out of 8192 */
```

Just 1759 AUs to implement **four** instances of a lookup table:

- each table has **256** entries, **8-bits** per entry
- entry values are **~random**

If implemented in RAM, this would take 8192 bits

```
/* PIPELINE=108 LOGIC=696 MUX=633 CYCLE=5 */
/* PIPELINE=36 LOGIC=106 MUX=207 CYCLE=5 */
```

# Beispiel: Konstantentabellen 2

## Beispiel



A. Koch

```
#define NBITS (12)
#define TABLESIZE (1 << NBITS)
#define INITIAL_REMAINDER (0xFFFFFFFF)
#define FINAL_XOR_VALUE (0xFFFFFFFF)

static se_uint<32> crcTable[TABLESIZE] = {
    0x00000000, 0x04c11db7, 0x09823b6e, 0x0d4326d9,
    0x130476dc, 0x17c56b6b, 0x1a864db2, 0x1e475005,
    . . .
};
static se_uint<32> remainder;

SE_FUNC void crc32_func( SE_INST CRC32_INIT, SE_INST CRC32, unsigned int in, WRA *out )
{
    se_uint<NBITS> inbits = ((se_uint<NBITS>)in)(0,NBITS-1);          // Reverse the bits!
    se_uint<NBITS> data  = (se_uint<NBITS>)( inbits ^ (remainder >> (32 - NBITS)) );
    remainder = CRC32_INIT ? INITIAL_REMAINDER : (crcTable[integer(data)] ^ (remainder << NBITS));

    *out = remainder(0,31) ^ FINAL_XOR_VALUE;
}

/*          Final resource usage report          */
/* Total AUs = 264 out of 4096                  */
/* Total MUs = 0 out of 8192                    */
```

# Beispiel: Konstantentabellen 2

## Diskussion



A. Koch

```
#define NBITS (12)
#define TABLESIZE (1 << NBITS)
#define INITIAL_REMAINDER (0xFFFFFFFF)
#define FINAL_XOR_VALUE (0xFFFFFFFF)

static se_uint<32> crcTable[TABLESIZE] = {
    0x00000000, 0x04c11db7, 0x09823b6e, 0x0d4326d9,
    0x130476dc, 0x17c56b6b, 0x1a864db2, 0x1e475005,
    . . .
};
static se_uint<32> remainder;

SE_FUNC void crc32_func( SE_INST CRC32_INIT, SE_INST CRC32, unsigned int in, WRA *out )
{
    se_uint<NBITS> inbits = ((se_uint<NBITS>)in)(0,NBITS-1);          // Reverse the bits!
    se_uint<NBITS> data  = (se_uint<NBITS>)( inbits ^ (remainder >> (32 - NBITS)) );
    remainder = CRC32_INIT ? INITIAL_REMAINDER : (crcTable[integer(data)] ^ (remainder << NBITS));

    *out = remainder(0,31) ^ FINAL_XOR_VALUE;
}

/* Final resource usage report */
/* Total AUs = 264 out of 4096 */
/* Total MUs = 0 out of 8192 */
```

Just 264 AUs to implement lookup table:

- table has **4096** entries, **32-bits** per entry
- entry values are **-random**

If implemented in RAM, this would take 131,072 bits  
(500x larger)



A. Koch

# Rekonfiguration

# Rekonfiguration



A. Koch

- Name einer Konfiguration: Basisname der `.xc`-Datei
  - Also enthält `foo.xc` eine Konfiguration namens `foo`
- Rekonfigurationszeit für ISEF: ca.  $100\mu\text{s}$
- Automatisches und manuelles Rekonfigurieren

# Automatische Rekonfiguration

## On-Demand bei Ausführen einer EI der Konfiguration



A. Koch

```
#include <s5000/sx-isef.h>
#include "isef_instruction.h"

void main() {
    WRA v1, v2, vOut;

    /* Auto Loading Enabled By Default */

    /* Use Instruction */
    FIR(v1, v2, &vOut);

    /*
     * If FIR doesn't exist in either of the ISEF, processor will take an exception.
     * The Exception Handler will
     *   locate the ISEF configuration with the given instruction
     *   decide which ISEF to load based on the LRU Bit set in hardware
     *   start the ISEF loading
     * Upon completion of the load; it returns from the exception
     *
     * If the ISEF was previously configured, the handler will first invalidate
     * the old configuration.
     */

    /* At this point the FIR Instruction is executed by the processor */
}
```

# Manuelle Rekonfiguration

Explizites Laden der Konfiguration, auch vor Benutzung einer EI



A. Koch

```
void main() {
    WRA v1, v2, vOut;

    /* Usage of Non Blocking API */
    error = sx_isef_load_by_name_async(sx_isef_a, "fir");

    /* Do Something - Typically takes 100 usecs to load the ISEF */
    process();

    /* Use FIR Instruction */
    FIR(v1, v2, &vOut);

    /*
     * For the first use of the FIR instruction the processor will take an exception
     * The Exception Handler will -
     *
     * If "fir" configuration is still loading; the exception handler waits for the
     * load to complete and then sets up the ISEF interface registers and exits out
     * of the exception handler
     *
     * If "fir" configuration is already loaded, the exception handler sets up the
     * ISEF interface registers and exits out of the exception handler
     */
}
```



A. Koch

# Speicher und DMA



# Übersicht über Speicher-Ressourcen



A. Koch

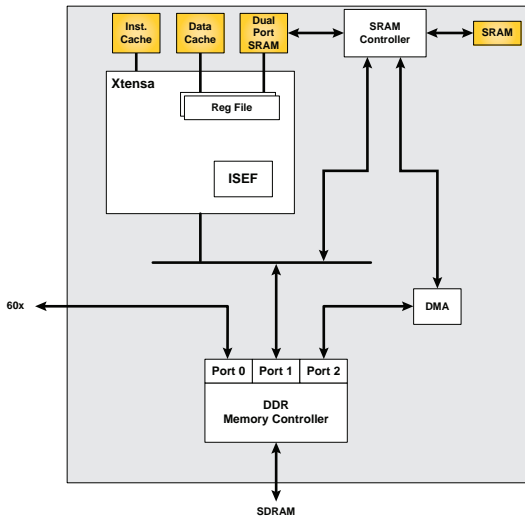

# Übersicht über Speicher-Ressourcen



A. Koch

- Daten-Cache: 32KB
  - “Write-Back”-Betriebsart
  - Auch Schreib-Zugriffe gecached
- Dual-Port-Data-RAM (DPDR): 32KB
  - Liefert Daten in einem Takt **garantiert** ohne Wartezyklen
  - Kann **gleichzeitig** von DMA-Controller und S5 Engine benutzt werden
  - Syntax:  

```
__attribute__ ((section(".dataram.data")))
```
- On-Chip Static RAM: 256KB
  - Liefert Daten in  $\approx 10$  Takten (Wartezyklen möglich!)
  - Syntax:  

```
__attribute__ ((section(".sram.data")))
```
- Externes Double-Data-Rate Dynamic RAM (DDR-DRAM): bis zu 2 GB
  - Liefert Daten in 40-50 Takten (Wartezyklen möglich!)

# Speicheraufteilung

Alle Ressourcen in einem Adressraum zugänglich



A. Koch

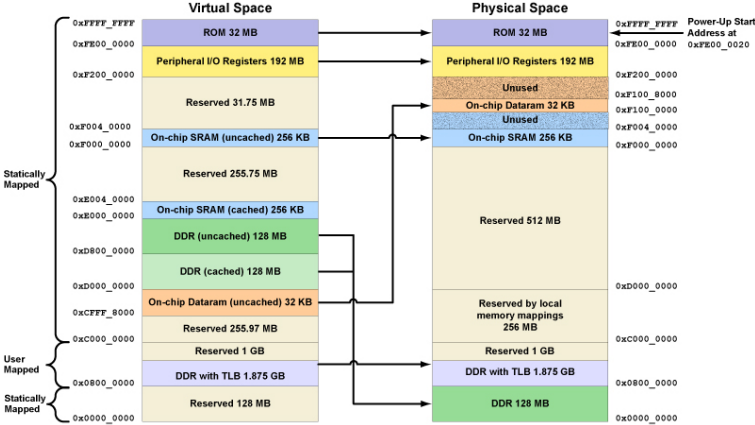

# Direct Memory Access (DMA)



## Bisher

- Xtensa V Pipeline füttert ISEF mit Daten
- Explizite Übergabe von Registerwerten
- Explizite LOAD/STORE-Anweisungen

A. Koch

## Alternative

- Datentransfers **unabhängig** von Xtensa V Pipeline
- Kann Daten-Cache **umgehen**
  - Sinnvoll bei Streaming
  - Hier **keine** temporale Lokalität
  - Cache-Effizienz eingeschränkt

# Speicherzugriffsmechanismen

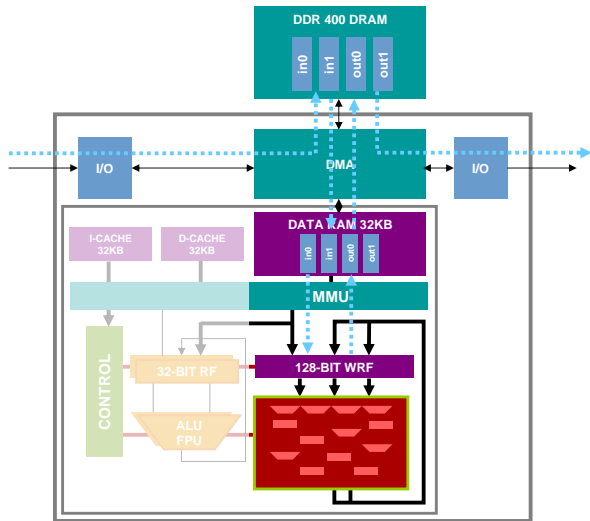

I/O →  
DDR-DRAM

A. Koch

DDR-DRAM  
→ DPDRAM

DPDRAM →  
WRF

WRF →  
DPDRAM

DPDRAM →  
DDR-DRAM

DDR-DRAM  
→ I/O

# Beispiel für Programmierung von DMA-Transfers



A. Koch

```
#include <sx-mmdma.h>

// Platz für zugewiesene DMA-Kanäle
sx_mmdma_chan *channelDDR2DPD; // von DDR-DRAM zu DPDRAM
sx_mmdma_chan *channelDPD2DDR; // von DPDRAM zu DDR-DRAM

// Steuerdaten für DMA-Transfer
sx_mmdma_chan_config transferDDR2DPD;
sx_mmdma_chan_config transferDPD2DDR;

// Dummy-Daten
int indata[256], outdata[256];

// Zwischenpuffer
int inbuffer[256] __attribute__((section(".dataram.data")));
int outbuffer[256] __attribute__((section(".dataram.data")));

main() {
    ...
    // neue DMA-Kanäle anlegen (beliebiger HW-Kanal, 1 Transfer pro Kanal)
    transferDDR2DPD.chan_num = transferDPD2DDR.chan_num = -1;
    transferDDR2DPD.num_desc_buf = transferDPD2DDR.num_desc_buf = 1;
    sx_mmdma_chan_init(&transferDDR2DPD, &channelDDR2DPD)
    sx_mmdma_chan_init(&transferDPD2DDR, &channelDPD2DDR)

    // 1. DMA Operation von DDR-DRAM indata nach buffer in DPDRAM starten
    sx_mmdma_memcpy(channelDDR2DPD, inbuffer, indata, sizeof(indata), 0);

    // warten, bis Daten vollständig übertragen
    while (sx_mmdma_get_num_pending(channelDDR2DPD) > 1)
        ;

    // Daten von inbuffer nach outbuffer verarbeiten (z.B. mit ISEF)
    process(inbuffer, outbuffer)

    // 2. DMA-Operation von DPDRAM nach DDR-DRAM outdata starten
    sx_mmdma_memcpy(channelDPD2DDR, outdata, outbuffer, sizeof(outdata), 0);

    // warten, bis Daten vollständig übertragen
    while (sx_mmdma_get_num_pending(channelDPD2DDR) > 1)
        ;

    // Kanäle schließen
    sx_mmdma_chan_close(channelDDR2DPD);
    sx_mmdma_chan_close(channelDPD2DDR);
    ...
}
```

# Details der DMA-Benutzung



A. Koch

- Auch mehrere **aufeinanderfolgende** Transfers automatisch startbar
  - Dann `num_desc_buf` auf benötigte Anzahl erhöhen
  - Transfers wie üblich starten
  - `sx_mmdma_get_num_pending` liefert die Zahl der noch abzuarbeitenden Transfers des Kanals
- Eigenschaften **je Kanal**
  - Ursprungs- und Zielspeichertyp
    - DDR-DRAM, SRAM, DPDRAM, PCI, GIB, ...
  - DMA-Deskriptor
  - ➡ Kann auch kompliziertere Transfers ausdrücken
- Eigenschaften **je Transfer**
  - Ursprungs- und Zieladresse
  - Transfergröße (in Bytes)

# Idee Scatter/Gather-DMA



A. Koch

- Bisher **lineare** Datentransfers
  - Zusammenhängende Ursprungs- und Zielspeicherbereiche
- Scatter
  - Verteilen von Daten über **unzusammenhängende** Speicherbereiche
- Gather
  - Zusammenführen von unzusammenhängenden Daten zu **einem** Bereich



# Scatter/Gather-DMA: Handhabung



A. Koch

- Charakterisiert durch
  - Stride (Schrittweite)
    - Anzahl von **aufeinanderfolgend übertragenen** Bytes
  - Skip (Überspringen)
    - Anzahl von **übersprungenen** (nicht übertragenen) Bytes
- Angaben **getrennt** für Ursprungs- und Zielspeicherbereiche
- Transfer erfolgt durch abwechselnde Stride/Skip-Schritte
- Bis angegebene Gesamtanzahl von Bytes übertragen
- Lineare Transfers haben Skip = 0
  - Nichts wird übersprungen
  - Alle Bytes werden übertragen



# Beispiel: Scatter/Gather-DMA

Kopieren einer 128x128 Untermatrix einer 512x512 Matrix

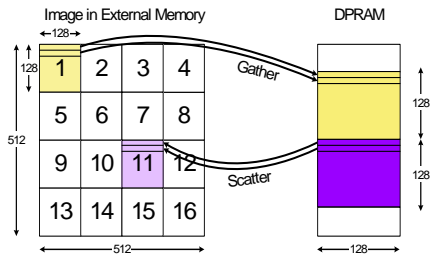

A. Koch

```
/* channel setup - Gather Function */
config.src_stride = 128; config.src_skip = 384;
sx_mmdma_chan_init (&config, &chID);

/* schedule memory-to-memory transfer */
sx_mmdma_memcpy (chID, dst, &src[0][0], 128*128, 0);

/* channel setup - Scatter Function */
config.dest_stride = 128; config.dest_skip = 384;
sx_mmdma_chan_init (&config, &chID);

/* schedule memory-to-memory transfer */
sx_mmdma_memcpy (chID, &dst[256][256], src, 128*128, 0);
```

# Interaktion von Speichersystemen

## Caches und DMA



A. Koch

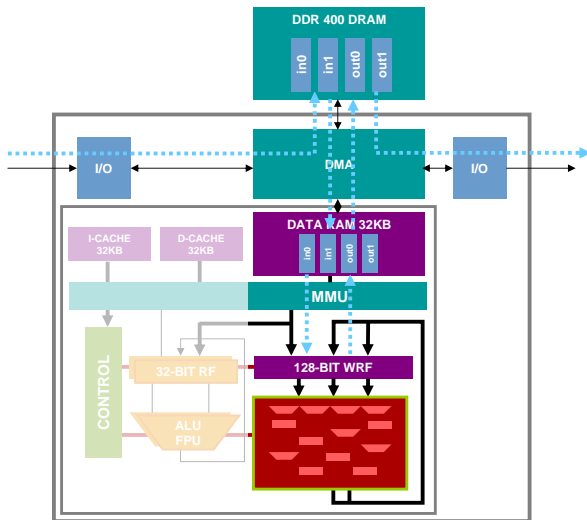

# Cache-DMA Interaktion

## Transfer **nach** DDR-DRAM: Problem?



A. Koch

```
/* Initialization Code @ Reset */
for (i = 0; i < 1024; i++)
    buffer_In_DDR[i] = 0;

/* Generate some data and store in buffer_In_Dataram */
process (buffer_In_Dataram);

/* DMA out to buffer_In_DDR[ ] */
sx_mmdma_memcpy (chID, buffer_In_DDR, buffer_In_Dataram, 1024, 0);

/* Wait for transfer to complete */
while (sx_mmdma_get_num_pending (chID) > 0) ;

/* Print to view computed data */
for (i = 0; i < 1024; i++)
    printf ("Buffer[%d] = %d\n", i, buffer_In_DDR[i])
```

# Cache-DMA Interaktion

## Transfer nach DDR-DRAM: Lösung



A. Koch

```
/* Initialization Code @ Reset */
for (i = 0; i < 1024; i++)
    buffer_In_DDR[i] = 0;

/* Generate some data and store in buffer_In_Dataram */
process (buffer_In_Dataram);

/* DMA out to buffer_In_DDR[ ] */
sx_mmdma_memcpy (chID, buffer_In_DDR, buffer_In_Dataram, 1024, 0);

/* Invalidate Data Cache Why? */
sx_dcache_region_invalidate (buffer_In_DDR, 1024);

/* Wait for transfer to complete */
while (sx_mmdma_get_num_pending (chID) > 0) ;

/* Print to view computed data */
for (i = 0; i < 1024; i++)
    printf ("Buffer[%d] = %d\n", i, buffer_In_DDR[i])
```

# Cache-DMA Interaktion

## Transfer nach DDR-DRAM: Lösung



A. Koch

```
/* Initialization Code @ Reset */
for (i = 0; i < 1024; i++)
    buffer_In_DDR[i] = 0;

/* Generate some data and store in buffer_In_Dataram */
process (buffer_In_Dataram);

/* DMA out to buffer_In_DDR[ ] */
sx_mmdma_memcpy (chID, buffer_In_DDR, buffer_In_Dataram, 1024, 0);

/* Invalidate Data Cache Why? */
sx_dcache_region_invalidate (buffer_In_DDR, 1024);

/* Wait for transfer to complete */
while (sx_mmdma_get_num_pending (chID) > 0) ;

/* Print to view computed data */
for (i = 0; i < 1024; i++)
    printf ("Buffer[%d] = %d\n", i, buffer_In_DDR[i])
```

### In sequence

1. Store to DDR
2. DMA to DDR
3. Load from DDR

Must invalidate data cache  
after DMA or load will get  
old data

# Cache-DMA Interaktion

## Transfer von DDR-DRAM: Problem?



A. Koch

```
/* Write data to buffer */
for (i = 0; i < 1024; i++)
    buffer_In_DDR[i] = function (i);

/* DMA from to buffer_In_DDR[ ] */
sx_mmdma_memcpy (chID, buffer_In_DDR, buffer_In_Dataram, 1024, 0);

/* Wait for transfer to complete */
while (sx_mmdma_get_num_pending (chID) > 0) ;

/* Print to view data */
for (i = 0; i < 1024; i++)
    printf ("Buffer[%d] = %d\n",i, buffer_In_Dataram[i])
```



# Cache-DMA Interaktion

## Transfer von DDR-DRAM: Lösung



A. Koch

```
/* Write data to buffer */
for (i = 0; i < 1024; i++)
    buffer_In_DDR[i] = function (i);

/* Writeback Data Cache Why? */
sx_dcache_region_writeback (buffer_In_DDR, 1024);

/* DMA from to buffer_In_DDR[ ] */
sx_mmdma_memcpy (chID, buffer_In_DDR, buffer_In_Dataram, 1024, 0);

/* Wait for transfer to complete */
while (sx_mmdma_get_num_pending (chID) > 0) ;

/* Print to view data */
for (i = 0; i < 1024; i++)
    printf ("Buffer[%d] = %d\n", i, buffer_In_Dataram[i])
```

# Cache-DMA Interaktion

## Transfer von DDR-DRAM: Lösung



A. Koch

```
/* Write data to buffer */
for (i = 0; i < 1024; i++)
    buffer_In_DDR[i] = function (i);

/* Writeback Data Cache Why? */
sx_dcache_region_writeback (buffer_In_DDR, 1024);

/* DMA from to buffer_In_DDR[ ] */
sx_mmdma_memcpy (chID, buffer_In_DDR, buffer_In_Dataram, 1024, 0);

/* Wait for transfer to complete */
while (sx_mmdma_get_num_pending (chID) > 0) ;

/* Print to view data */
for (i = 0; i < 1024; i++)
    printf ("Buffer[%d] = %d\n", i, buffer_In_Dataram[i])
```

In sequence

1. Store to DDR
2. DMA from DDR

Must writeback data cache  
before DMA or DMA will get  
old data



- Pipelining-Details
- Loop Unrolling
- Optimierung von Els
- Konstantentabellen
- Rekonfiguration
- Heterogene Speicherressourcen
- DMA